



## **Acousto-Optic Deflector Driver**

**Including: Basic Deflector Alignment**

### **Instruction Manual**

#### **RFA3080-2 Series Rev 5**

Models -

RFA3080-2 : 65-95MHz 5W per channel  
RFA3080-2-25 : 65-95MHz 25W per channel

All models: 10V Tuning Input, 10V Analog Modulation Input, unless stated

ISOMET CORP, 10342 Battleview Parkway, Manassas, VA 20109, USA.  
Tel: (703) 321 8301, Fax: (703) 321 8546, e-mail: [isomet@isomet.com](mailto:isomet@isomet.com)  
[www.ISOMET.com](http://www.ISOMET.com)  
ISOMET (UK) Ltd, 18 Llantarnam Park, Cwmbran, Torfaen, NP44 3AX, UK.  
Tel: +44 1633-872721, Fax: +44 1633 874678, e-mail: [isomet@isomet.co.uk](mailto:isomet@isomet.co.uk)



1. GENERAL

The RFA3080-2 series combine a high speed VCO source with dual RF power amplifiers. A schematic is shown in figure 1. These drivers are specifically designed to operate with Isomet Beam Steered acousto-optic deflectors. The driver accepts a tuning voltage between approximately +0 volts and +10 volts and provides an RF output matched to the acousto-optic deflector frequency range. The driver also accepts an analogue modulating signal. This permits the amplitude control of the RF output and is typically applied to provide intensity control across the scan range.

A summary of the driver specification is shown in the following table:

<u>Model</u>	<u>Use With</u>	<u>Output Frequency</u>	<u>Output Power</u>
RFA3080-2	D1312-T80L series	65 - 95MHz	> 5 Watt / channel
RFA3080-2-25	D1346-T80L series	65 - 95MHz	> 25 Watt / channel

Figure 2 is a block diagram of the Driver. The output frequency of the driver is controlled by a hybridized varactor oscillator circuit. The capacitance of the internal varactor is a function of the applied tuning voltage. The output frequency is proportional to the input tuning voltage with a pseudo linear MHz/volt characteristic. The start frequency corresponds to a tuning voltage of 0.0 volts and is pre-set to the AODs lowest scan frequency (e.g. 65MHz for the D1312). A table of output frequency versus input tuning voltage is supplied with each driver. The frequency linearity is typically  $\pm 1.0\%$ , and frequency stability is typically  $\pm 0.25\%$ .

A balanced diode ring mixer is used to amplitude-modulate the RF carrier. A video input swing of 0 to +10 volt (positive with respect to ground) results in 100% depth of modulation.

**The video input level must not exceed 15 volts**

The amplitude-modulated r-f from the ring modulator is applied to a pre-amplifier stage and then to the splitter / phase delay network. The final power amplifier stages are designed to operate at full rated power into a  $50\Omega$  load with 100% duty cycle.

FRONT PANEL CONTROLS

The multi-turn variable potentiometer situated to the right of the front panel LED's allows adjustment of start frequency (FOS). This is the frequency output at 0V tuning voltage input.

For optimum scan flatness, the operating frequency range may be need to be centred +/- 10% from the nominal centre. The limits of this adjustment cover the full tuning range. This allows the driver output frequency to be set at any fixed point across the frequency range without the need for a tuning voltage input.

The single-turn variable potentiometer (PWR ADJ) situated to the left of the front panel LED's sets the maximum RF power level. This is level that will be achieved for the maximum Modulation input

**NOTE : Maximum power = fully clockwise**

LED indicators

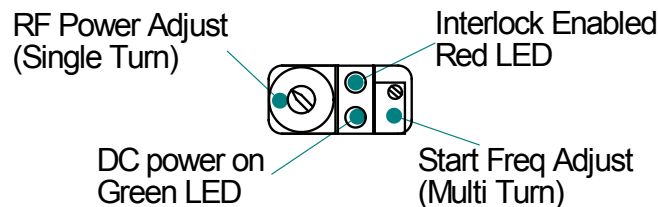

DC supply

Filtered feed through Solder connection.

A low impedance source of d-c power is required for operation of the RFA3080. The required voltage is +24Vdc at a current drain of approximately 2.5A (-5) or 4A for the -25. The external power source should be regulated to ± 2% and the power supply ripple voltage should be less than 200mV for best results.

Higher RF output power is achieved at 28Vdc.

**Water cooling is mandatory. The heatsink temperature must not exceed 70°C.**

**SERIOUS DAMAGE TO THE AMPLIFIER MAY RESULT IF THE TEMPERATURE EXCEEDS 70°C.  
SERIOUS DAMAGE TO THE AMPLIFIER MAY ALSO RESULT IF THE RF OUTPUT CONNECTOR IS OPERATED OPEN-CIRCUITED OR SHORT-CIRCUITED.**

### 3. INSTALLATION AND ADJUSTMENT

- 3.1 Connect cooling water at a flow rate greater than 0.5 litres/minute at less than 25 degC (Push-fit water connections are provided to suit 8mm OD plastic tubing.)
- 3.2 With the DC supply power OFF, connect the +24Vdc to the screw terminals. The '+' terminal is marked. DO NOT APPLY POWER. (+28Vdc may be used, with increased maximum RF power).
- 3.3 Connect the (2) RF output SMA jacks to the (2) SMA RF inputs of the acousto-optic deflector (or a 50Ω RF load, if it is desired to measure the modulator RF output power). The order of connection is important. See Figure 4. The deflector will not be damaged if the order is incorrect but the amplifier outputs must be terminated. If the RF cable connections are incorrect, the deflection efficiency will vary considerably as the deflector frequency is changed.

e.g. for an input laser beam aligned slightly towards the RF connector end of the AO deflector, the correct order is:

- Connect the phase delayed output J2 (DLY) of the RFA3080-2- driver to the input RF1 of the AO deflector.
- Connect the output X1 of the driver to the input RF2 of the AO deflector.

The cable lengths from the amplifier to the two RF connections of the deflector must be equal.

- 3.4 Connect the Interlock of the acousto-optic deflector (SMC or 3-pin mini snap connector) to the enable inputs on the 9-pin D-type connector of the RFA3080-2.

#### SMA

- Connect pin 9 of 'D' to the centre pin of the SMC
- Connect pin 4 of 'D' to the outer ground of the SMC.

Or

- Connect pin 9 of 'D' to pin 2 of the mini snap connector
- Connect pin 4 of 'D' to pin 1 of the mini snap connector

( D-type pin 4 is internally connected to 0V)

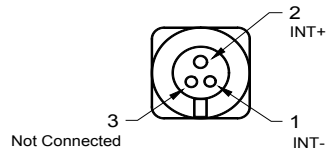

The interlock connection becomes open circuit disabling the RF output, if the temperature of the modulator exceeds 32°C or the internal driver temperature exceeds 43°C. An LED indicator illuminates when the Interlocks are closed, and the RF is enabled.

3.5 Connect the tuning voltage source to the D-type connector

- Connect the tuning signal ( 0,0 -10.0V) to pin 1
- Connect the signal return (0V) to pin 6

3.6 Connect the amplitude control source to the D-type connector.

- Connect the modulation signal ( 0,0 - 10.0V) to pin 8
- Connect the signal return (0V) to pin 3

3.7 Adjustment of the RF output power is best done with amplifier connected to the acousto-optic modulator.

The optimum RF power level required for the deflector to produce maximum first order intensity depends on laser wavelength. Applying RF power in excess of this optimum level will cause a decrease in first order intensity (a false indication of insufficient RF power) and makes accurate Bragg alignment difficult. It is therefore recommended that initial alignment be performed at a low RF power level.

3.8 Locate the PWR ADJ access on the driver end plate.

3.9 With an insulated alignment tool or screwdriver rotate the PWR ADJ potentiometer fully anti-clockwise (CCW) i.e. OFF, then clockwise (CW) approx' 1/2 turn.

3.10 Apply +24 / + 28V DC to the amplifier. Turn on the Cooling water.

3.11 Apply a 10.0V constant modulation signal to the modulation input, pin-8 of the D-type connector.

3.12 Apply a 5.0V constant tuning voltage to the tuning input, pin-1 of the D-type connector. This will operate the deflector at its mid-scan position.



A frequency monitor signal (Fmon) is available on the front panel BNC (if fitted). This signal is approximately 100-200mVpp at the tuned frequency. It does not indicate power level.

- 3.13 Apply approximately half the required RF power at the centre frequency.

For the Isomet RFA3080-2- this is achieved by adjusting the pot 1/3 to 1/2 clockwise from the fully anti-clockwise position. Turn on DC power.

Align the deflector head to ensure that the incident light beam is centred in the active aperture of the deflector. The following explanation assumes the light beam is directed slightly toward the transducer (connector end) of the deflector.

Gently rotate the deflector slightly until deflection of the light beam occurs. The deflection will occur in the horizontal plane. Select the strongest diffracted spot and monitor the light intensity by using either a photo detector or a light power meter. Re-adjust the Bragg angle for maximum deflected light intensity. Fine tuning of the incident light beam position may be necessary for optimum results.

- 3.14 After Bragg angle has been optimized, slowly increase the RF power (rotate PWR ADJ CW) until maximum first order intensity is obtained. This intensity value is  $I_{SAT}$ .

- 3.15 To equalise deflection efficiency across the extremes of the scan, alternate between the minimum and maximum desired frequencies (0.0V and 10.0V tuning voltage resp') and adjust the Bragg angle to give the same efficiency at both positions. Fine tuning of the incident Bragg angle and RF power may be necessary for optimum results.

Sweeping the freq' input should result in a continuous deflected line output. If significant peaks and troughs are noted across the sweep, it is probable that the phase delayed outputs of the RFA3080-2- are connected to the incorrect inputs of the AO deflector. (see Fig 4)

The coax lead lengths between the two outputs of the RFA3080-2- and the beam steered AO deflector should be equal unless otherwise instructed. Unequal lengths of more than a 1cm would introduce a phase error. Within limits, small changes in the relative lead lengths can be used to fine tune the deflector sweep response, although this is not usually required. The Bragg angle would need re-adjustment.

- 3.16 The driver and deflector are now ready for use.



#### 4. THERMAL EFFECTS

We must consider the thermal effects of this device - both due to optical and acoustic absorption. The majority of heat is generated by RF drive power. As the temperature of the material increases beyond the recommended level, undesired refractive index changes will occur in the material. This results in beam distortion. Ultimately, the crystal will crack due to thermal stresses, if excessive RF power is applied.

#### 5. MAINTENANCE

##### 5.1 Cleaning

It is of utmost importance that the optical apertures of the deflector optical head be kept clean and free of contamination. When the device is not in use, the apertures may be protected by a covering of masking tape. When in use, frequently clean the apertures with a pressurized jet of filtered, dry air.

It will probably be necessary in time to wipe the coated window surfaces of atmospherically deposited films. Although the coatings are hard and durable, care must be taken to avoid gouging of the surface and residue of the cleaning solution. It is suggested that the coatings be wiped with a soft ball of brushed (short fibres removed) cotton, slightly moistened with clean alcohol. Before the alcohol has had time to dry on the surface, wipe again with dry cotton in a smooth, continuous stroke. Examine the surface for residue and, if necessary, repeat the cleaning.

#### 6 Troubleshooting

No troubleshooting procedures are proposed other than a check of alignment and operating procedure. If difficulties arise, take note of the symptoms and contact the manufacturer.

##### 6.1 Repairs

In the event of deflector malfunction, discontinue operation and immediately contact the manufacturer or his representative. Due to the high sensitive of tuning procedures and the possible damage, which may result, no user repairs are allowed. Evidence that an attempt has been made to open the optical head will void the manufacturer's warranty.

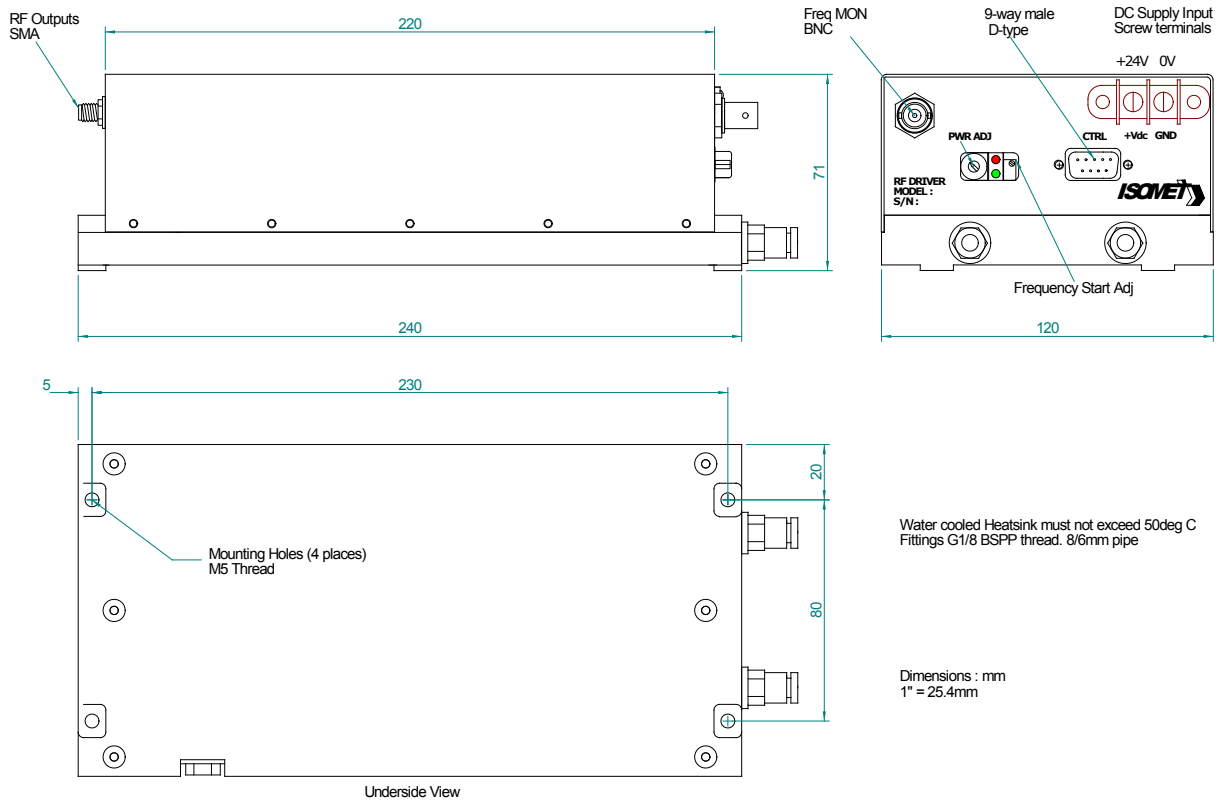

Control signals -	:	9 pin 'D' type
Tuning Voltage (0 -10V)	:	+sig pn1, -rtn pn6
Amplitude Control (0 – 10V)	:	+sig pn8, -rtn pn3
Enable/Interlock Control (Low = On)	:	+sig pn9, -rtn pn4
Digital Gate Input (NC or High = On)	:	+sig pn7, -sig pn2
Internal 10K ohm pull up to 12V		

Figure 1, RFA3080-2- driver



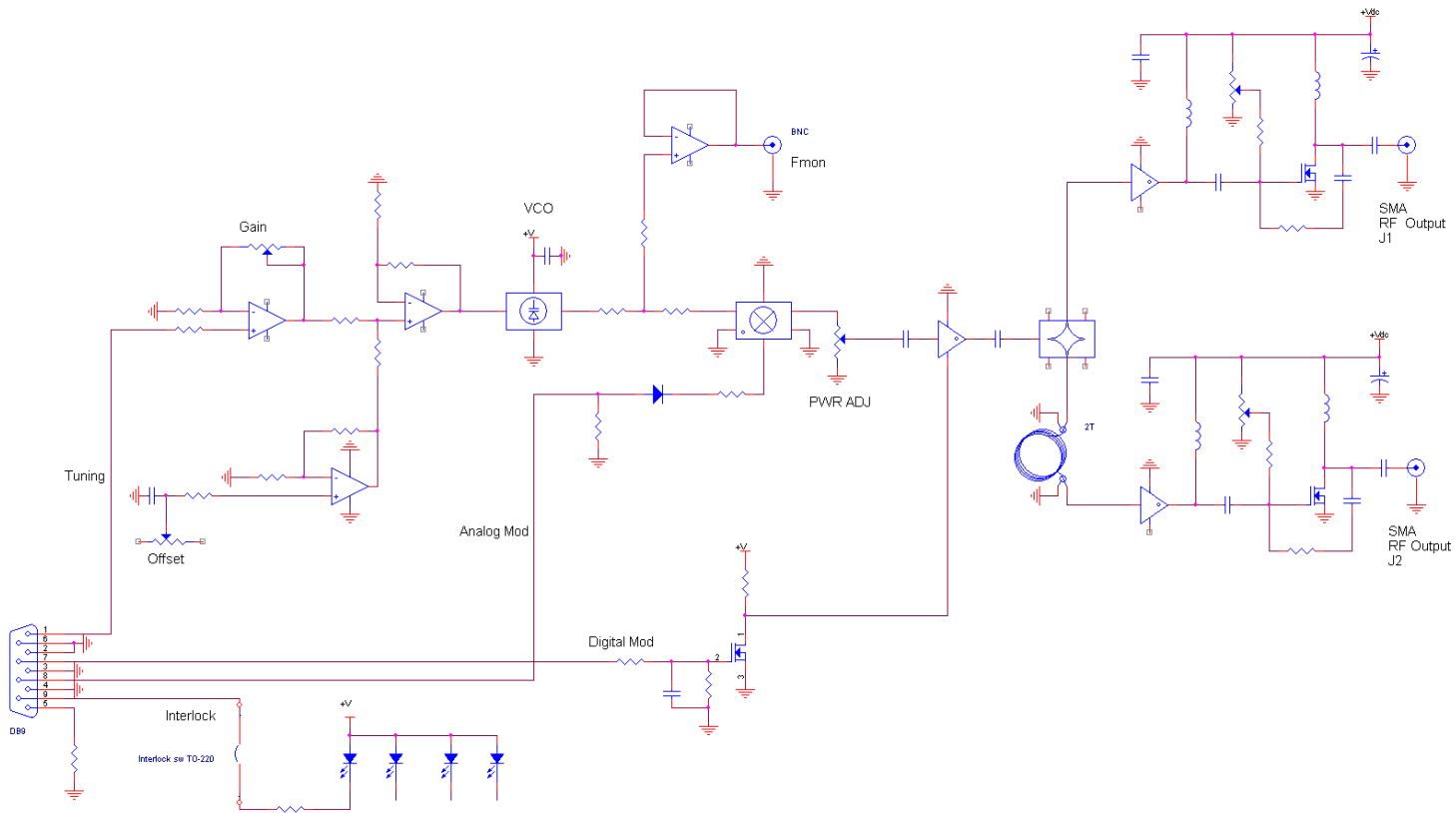

Figure 2, Driver Block Diagram

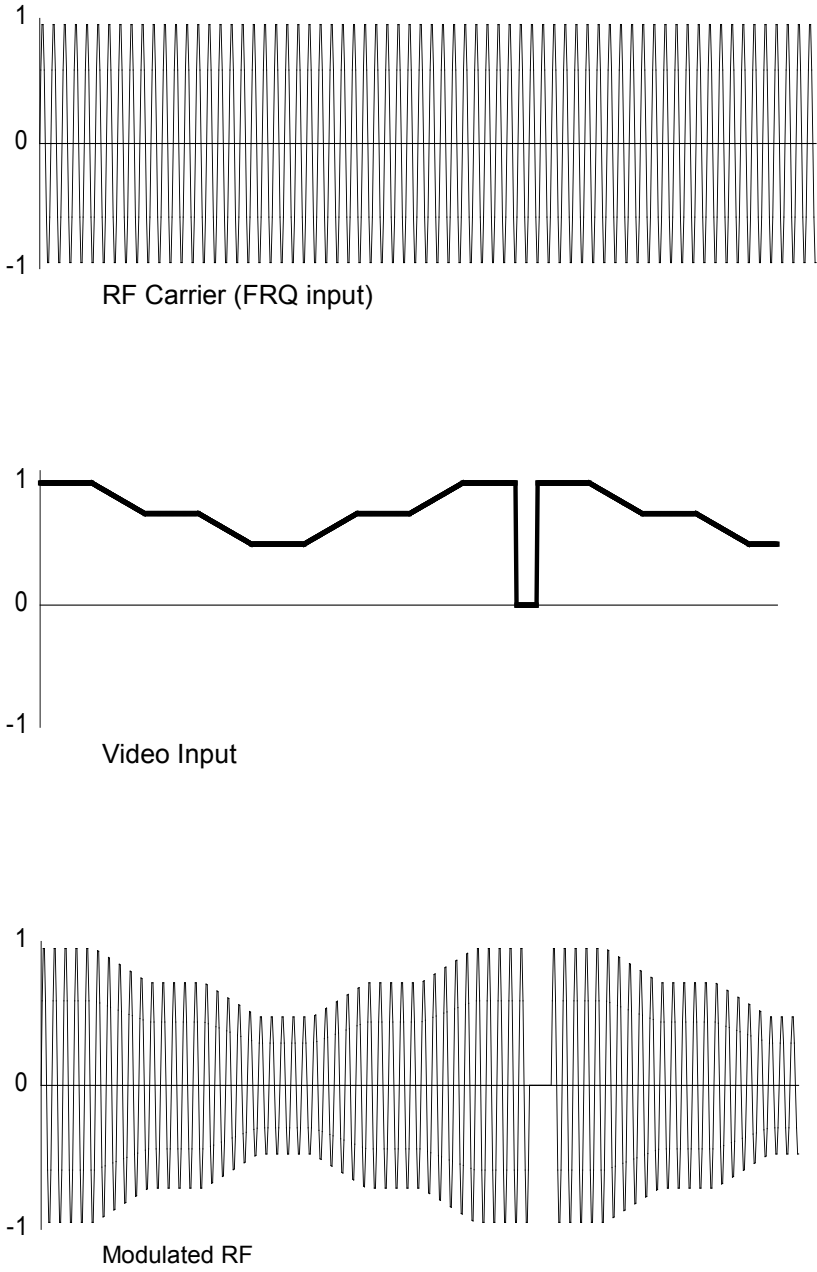
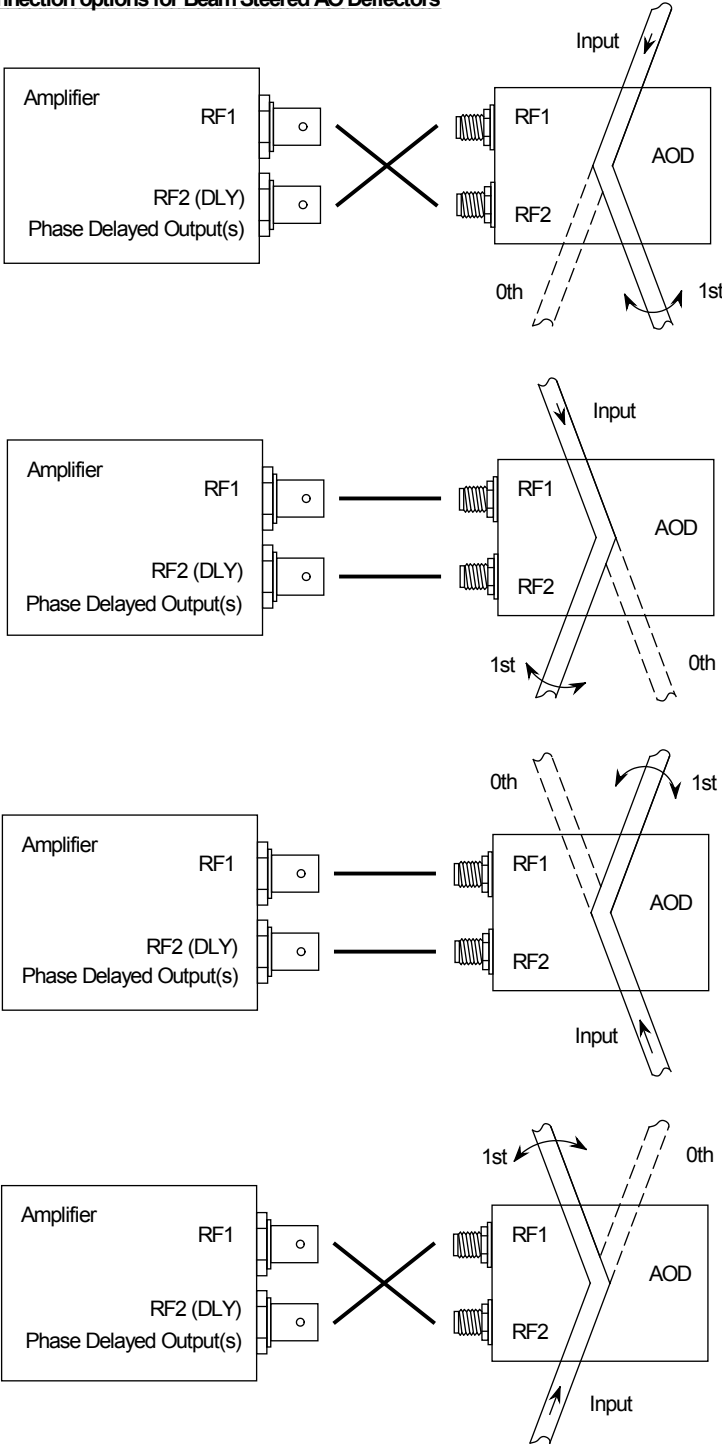

Figure 3, Typical Amplitude Modulation Waveforms

Connection options for Beam Steered AO Deflectors



Correct orientation as viewed from top of AOD  
(Connector identification may differ)

Figure 4

**Simplified Schematic of an acousto optic deflector and tunable driver**

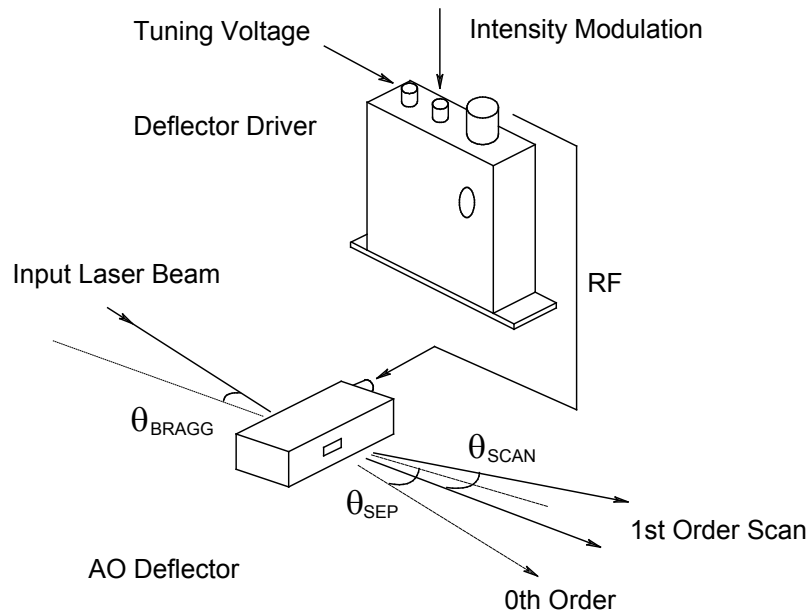

The input Bragg angle, relative to a normal to the optical surface and in the plane of deflection is given by:

$$\theta_{\text{BRAGG}} = \frac{\lambda \cdot f_c}{2 \cdot v}$$

The separation angle between the zeroth order and mid scan point of the first order is given by:

$$\theta_{\text{SEP}} = \frac{\lambda \cdot f_c}{v}$$

The first order scan angle is given by:

$$\theta_{\text{SCAN}} = \frac{\lambda \cdot \delta f}{v}$$

The access time or time aperture is given by:

$$T_{\text{acc}} = d/v$$

- where :
- $\lambda$  = wavelength
  - $\delta f$  = scan frequency bandwidth
  - $f_c$  = centre frequency
  - $v$  = acoustic velocity of the crystal material;  
Ge = 5.5mm/us, Quartz 5.7mm/us, TeO<sub>2</sub>(L)=4.2mm/us
  - $d$  = beam diameter

Figure 5, Deflector Parameters

Typical orientations

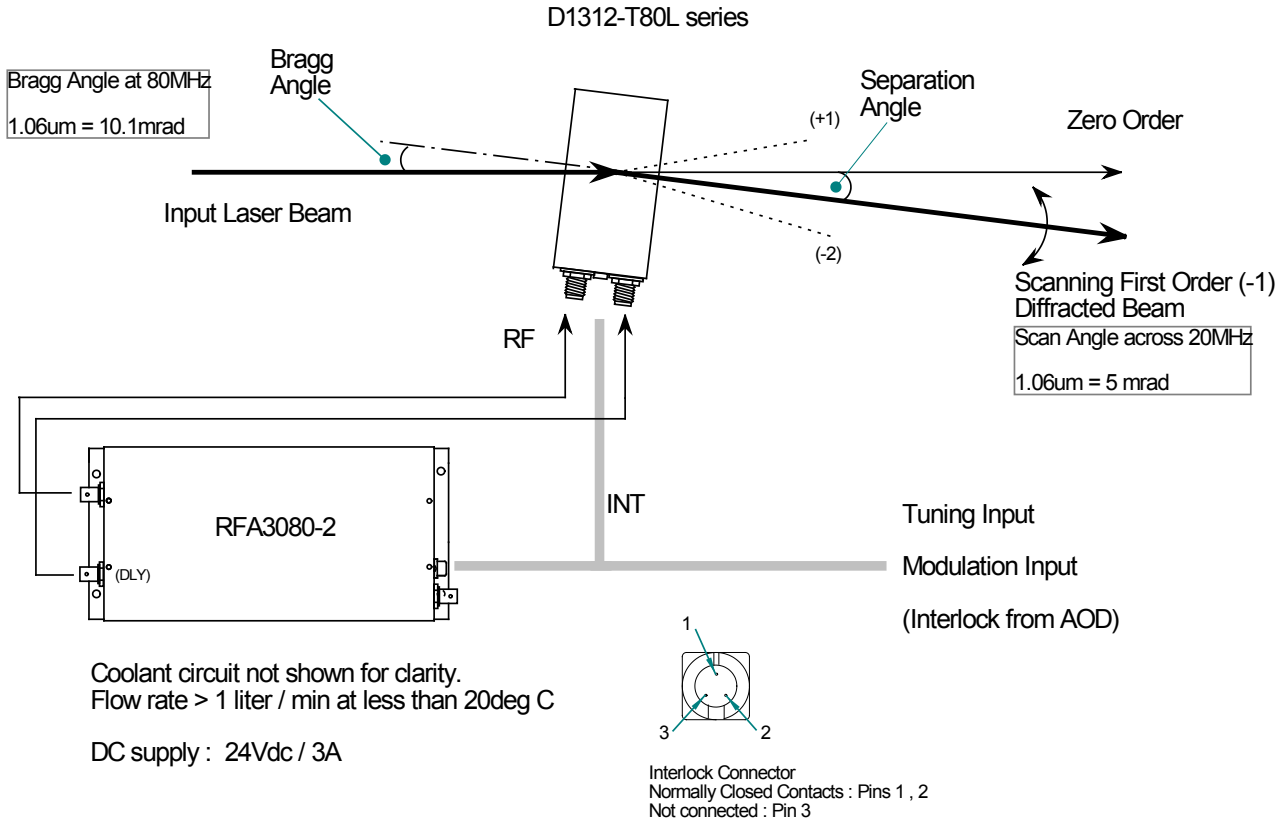

**RFA 3080-2**

**Connection Summary**

1.0 'D' Type Control Connection

<u>Signal</u>	<u>Type</u>	<u>Pin out connection</u>
Tuning Input 0.0V(min) to 10.0V(max)	Input	Signal pin 1 Return pin 6
Analogue Modulation 0.0V(off) to 10.0V(on)	Input	Signal pin 8 Return pin 3
Interlock / Enable (Low = On (Connect to AO device 'INT')	Input	Signal pin 9 Return pin 4
Digital Gate Input (NC or High = On) Internal 10K ohm pull up to 12V	Input	Signal pin 7 Return pin 2

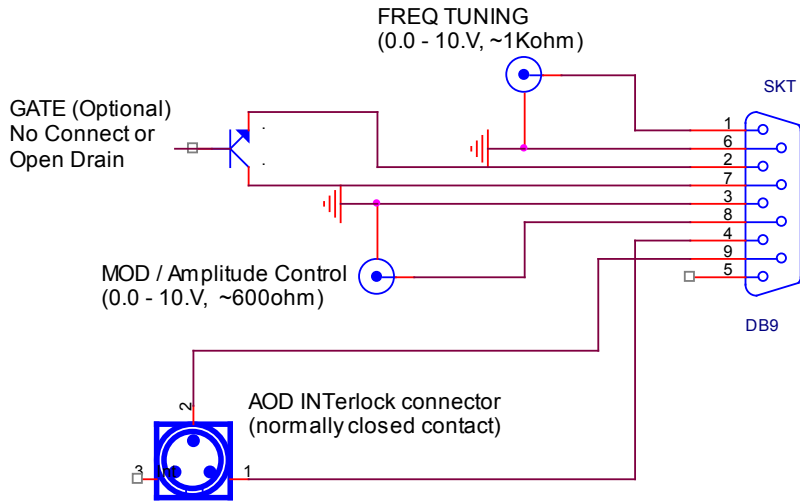

2.0 Mounting Holes

- 4 x M5 by 10 mm deep.
- 1 x M6 by 12 mm (underside)